



FHSST Authors

**The Free High School Science Texts:  
Textbooks for High School Students  
Studying the Sciences  
Physics  
Grades 10 - 12**

**Version 0  
November 9, 2008**

Copyright 2007 "Free High School Science Texts"

Permission **is** granted to copy, distribute and/or modify this document under the terms of the GNU Free Documentation License, Version 1.2 or any later version published by the Free Software Foundation; with no Invariant Sections, no Front-Cover Texts, and no Back-Cover Texts. A copy of the license is included in the section entitled "GNU Free Documentation License".



**STOP!!!!**

Did you notice the **FREEDOMS** we've granted you?

Our copyright license is **different!** It grants freedoms rather than just imposing restrictions like all those other textbooks you probably own or use.

- We know people copy textbooks illegally but we would LOVE it if you copied our's - go ahead copy to your hearts content, **legally!**
- Publishers' revenue is generated by controlling the market, we don't want any money, go ahead, distribute our books far and wide - we DARE you!
- Ever wanted to change your textbook? Of course you have! Go ahead, change ours, make your own version, get your friends together, rip it apart and put it back together the way you like it. That's what we really want!
- Copy, modify, adapt, enhance, share, critique, adore, and contextualise. Do it all, do it with your colleagues, your friends, or alone but get involved! Together we can overcome the challenges our complex and diverse country presents.
- So what is the catch? The only thing you can't do is take this book, make a few changes and then tell others that they can't do the same with your changes. It's share and share-alike and we know you'll agree that is only fair.
- These books were written by volunteers who want to help support education, who want the facts to be freely available for teachers to copy, adapt and re-use. Thousands of hours went into making them and they are a gift to everyone in the education community.

---

## FHSST Core Team

Mark Horner ; Samuel Halliday ; Sarah Blyth ; Rory Adams ; Spencer Wheaton

## FHSST Editors

Jaynie Padayachee ; Joanne Boule ; Diana Mulcahy ; Annette Nell ; René Toerien ; Donovan  
Whitfield

## FHSST Contributors

Rory Adams ; Prashant Arora ; Richard Baxter ; Dr. Sarah Blyth ; Sebastian Bodenstein ;  
Graeme Broster ; Richard Case ; Brett Cocks ; Tim Crombie ; Dr. Anne Dabrowski ; Laura  
Daniels ; Sean Dobbs ; Fernando Durrell ; Dr. Dan Dwyer ; Frans van Eeden ; Giovanni  
Franzoni ; Ingrid von Glehn ; Tamara von Glehn ; Lindsay Glesener ; Dr. Vanessa Godfrey ; Dr.  
Johan Gonzalez ; Hemant Gopal ; Umeshree Govender ; Heather Gray ; Lynn Greeff ; Dr. Tom  
Gutierrez ; Brooke Haag ; Kate Hadley ; Dr. Sam Halliday ; Asheena Hanuman ; Neil Hart ;  
Nicholas Hatcher ; Dr. Mark Horner ; Robert Hovden ; Mfandaidza Hove ; Jennifer Hsieh ;  
Clare Johnson ; Luke Jordan ; Tana Joseph ; Dr. Jennifer Klay ; Lara Kruger ; Sihle Kubheka ;  
Andrew Kubik ; Dr. Marco van Leeuwen ; Dr. Anton Machacek ; Dr. Komal Maheshwari ;  
Kosma von Maltitz ; Nicole Masureik ; John Mathew ; JoEllen McBride ; Nikolai Meures ;  
Riana Meyer ; Jenny Miller ; Abdul Mirza ; Asogan Moodaly ; Jothi Moodley ; Nolene Naidu ;  
Tyrone Negus ; Thomas O'Donnell ; Dr. Markus Oldenburg ; Dr. Jaynie Padayachee ;  
Nicolette Pekeur ; Sirika Pillay ; Jacques Plaut ; Andrea Prinsloo ; Joseph Raimondo ; Sanya  
Rajani ; Prof. Sergey Rakityansky ; Alastair Ramlakan ; Razvan Remsing ; Max Richter ; Sean  
Riddle ; Evan Robinson ; Dr. Andrew Rose ; Bianca Ruddy ; Katie Russell ; Duncan Scott ;  
Helen Seals ; Ian Sherratt ; Roger Sieloff ; Bradley Smith ; Greg Solomon ; Mike Stringer ;  
Shen Tian ; Robert Torregrosa ; Jimmy Tseng ; Helen Waugh ; Dr. Dawn Webber ; Michelle  
Wen ; Dr. Alexander Wetzler ; Dr. Spencer Wheaton ; Vivian White ; Dr. Gerald Wigger ;  
Harry Wiggins ; Wendy Williams ; Julie Wilson ; Andrew Wood ; Emma Wormauld ; Sahal  
Yacoob ; Jean Youssef

Contributors and editors have made a sincere effort to produce an accurate and useful resource.  
Should you have suggestions, find mistakes or be prepared to donate material for inclusion,  
please don't hesitate to contact us. We intend to work with all who are willing to help make  
this a continuously evolving resource!

[www.fhsst.org](http://www.fhsst.org)

---

# Contents

<b>I</b>	<b>Introduction</b>	<b>1</b>
1	What is Physics?	3
<b>II</b>	<b>Grade 10 - Physics</b>	<b>5</b>
<b>2</b>	<b>Units</b>	<b>9</b>
2.1	Introduction . . . . .	9
2.2	Unit Systems . . . . .	9
2.2.1	SI Units . . . . .	9
2.2.2	The Other Systems of Units . . . . .	10
2.3	Writing Units as Words or Symbols . . . . .	10
2.4	Combinations of SI Base Units . . . . .	12
2.5	Rounding, Scientific Notation and Significant Figures . . . . .	12
2.5.1	Rounding Off . . . . .	12
2.5.2	Error Margins . . . . .	13
2.5.3	Scientific Notation . . . . .	13
2.5.4	Significant Figures . . . . .	15
2.6	Prefixes of Base Units . . . . .	15
2.7	The Importance of Units . . . . .	17
2.8	How to Change Units . . . . .	17
2.8.1	Two other useful conversions . . . . .	19
2.9	A sanity test . . . . .	19
2.10	Summary . . . . .	19
2.11	End of Chapter Exercises . . . . .	21
<b>3</b>	<b>Motion in One Dimension - Grade 10</b>	<b>23</b>
3.1	Introduction . . . . .	23
3.2	Reference Point, Frame of Reference and Position . . . . .	23
3.2.1	Frames of Reference . . . . .	23
3.2.2	Position . . . . .	25
3.3	Displacement and Distance . . . . .	28
3.3.1	Interpreting Direction . . . . .	29
3.3.2	Differences between Distance and Displacement . . . . .	29
3.4	Speed, Average Velocity and Instantaneous Velocity . . . . .	31

3.4.1	Differences between Speed and Velocity . . . . .	35
3.5	Acceleration . . . . .	38
3.6	Description of Motion . . . . .	39
3.6.1	Stationary Object . . . . .	40
3.6.2	Motion at Constant Velocity . . . . .	41
3.6.3	Motion at Constant Acceleration . . . . .	46
3.7	Summary of Graphs . . . . .	48
3.8	Worked Examples . . . . .	49
3.9	Equations of Motion . . . . .	54
3.9.1	Finding the Equations of Motion . . . . .	54
3.10	Applications in the Real-World . . . . .	59
3.11	Summary . . . . .	61
3.12	End of Chapter Exercises: Motion in One Dimension . . . . .	62
<b>4</b>	<b>Gravity and Mechanical Energy - Grade 10</b>	<b>67</b>
4.1	Weight . . . . .	67
4.1.1	Differences between Mass and Weight . . . . .	68
4.2	Acceleration due to Gravity . . . . .	69
4.2.1	Gravitational Fields . . . . .	69
4.2.2	Free fall . . . . .	69
4.3	Potential Energy . . . . .	73
4.4	Kinetic Energy . . . . .	75
4.4.1	Checking units . . . . .	77
4.5	Mechanical Energy . . . . .	78
4.5.1	Conservation of Mechanical Energy . . . . .	78
4.5.2	Using the Law of Conservation of Energy . . . . .	79
4.6	Energy graphs . . . . .	82
4.7	Summary . . . . .	83
4.8	End of Chapter Exercises: Gravity and Mechanical Energy . . . . .	84
<b>5</b>	<b>Transverse Pulses - Grade 10</b>	<b>87</b>
5.1	Introduction . . . . .	87
5.2	What is a <i>medium</i> ? . . . . .	87
5.3	What is a <i>pulse</i> ? . . . . .	87
5.3.1	Pulse Length and Amplitude . . . . .	88
5.3.2	Pulse Speed . . . . .	89
5.4	Graphs of Position and Velocity . . . . .	90
5.4.1	Motion of a Particle of the Medium . . . . .	90
5.4.2	Motion of the Pulse . . . . .	92
5.5	Transmission and Reflection of a Pulse at a Boundary . . . . .	96
5.6	Reflection of a Pulse from Fixed and Free Ends . . . . .	97
5.6.1	Reflection of a Pulse from a Fixed End . . . . .	97

5.6.2	Reflection of a Pulse from a Free End . . . . .	98
5.7	Superposition of Pulses . . . . .	99
5.8	Exercises - Transverse Pulses . . . . .	102
<b>6</b>	<b>Transverse Waves - Grade 10</b>	<b>105</b>
6.1	Introduction . . . . .	105
6.2	What is a <i>transverse wave</i> ? . . . . .	105
6.2.1	Peaks and Troughs . . . . .	106
6.2.2	Amplitude and Wavelength . . . . .	107
6.2.3	Points in Phase . . . . .	109
6.2.4	Period and Frequency . . . . .	110
6.2.5	Speed of a Transverse Wave . . . . .	111
6.3	Graphs of Particle Motion . . . . .	115
6.4	Standing Waves and Boundary Conditions . . . . .	118
6.4.1	Reflection of a Transverse Wave from a Fixed End . . . . .	118
6.4.2	Reflection of a Transverse Wave from a Free End . . . . .	118
6.4.3	Standing Waves . . . . .	118
6.4.4	Nodes and anti-nodes . . . . .	122
6.4.5	Wavelengths of Standing Waves with Fixed and Free Ends . . . . .	122
6.4.6	Superposition and Interference . . . . .	125
6.5	Summary . . . . .	127
6.6	Exercises . . . . .	127
<b>7</b>	<b>Geometrical Optics - Grade 10</b>	<b>129</b>
7.1	Introduction . . . . .	129
7.2	Light Rays . . . . .	129
7.2.1	Shadows . . . . .	132
7.2.2	Ray Diagrams . . . . .	132
7.3	Reflection . . . . .	132
7.3.1	Terminology . . . . .	133
7.3.2	Law of Reflection . . . . .	133
7.3.3	Types of Reflection . . . . .	135
7.4	Refraction . . . . .	137
7.4.1	Refractive Index . . . . .	139
7.4.2	Snell's Law . . . . .	139
7.4.3	Apparent Depth . . . . .	143
7.5	Mirrors . . . . .	146
7.5.1	Image Formation . . . . .	146
7.5.2	Plane Mirrors . . . . .	147
7.5.3	Ray Diagrams . . . . .	148
7.5.4	Spherical Mirrors . . . . .	150
7.5.5	Concave Mirrors . . . . .	150

7.5.6	Convex Mirrors . . . . .	153
7.5.7	Summary of Properties of Mirrors . . . . .	154
7.5.8	Magnification . . . . .	154
7.6	Total Internal Reflection and Fibre Optics . . . . .	156
7.6.1	Total Internal Reflection . . . . .	156
7.6.2	Fibre Optics . . . . .	161
7.7	Summary . . . . .	163
7.8	Exercises . . . . .	164
<b>8</b>	<b>Magnetism - Grade 10</b>	<b>167</b>
8.1	Introduction . . . . .	167
8.2	Magnetic fields . . . . .	167
8.3	Permanent magnets . . . . .	169
8.3.1	The poles of permanent magnets . . . . .	169
8.3.2	Magnetic attraction and repulsion . . . . .	169
8.3.3	Representing magnetic fields . . . . .	170
8.4	The compass and the earth's magnetic field . . . . .	173
8.4.1	The earth's magnetic field . . . . .	175
8.5	Summary . . . . .	175
8.6	End of chapter exercises . . . . .	176
<b>9</b>	<b>Electrostatics - Grade 10</b>	<b>177</b>
9.1	Introduction . . . . .	177
9.2	Two kinds of charge . . . . .	177
9.3	Unit of charge . . . . .	177
9.4	Conservation of charge . . . . .	177
9.5	Force between Charges . . . . .	178
9.6	Conductors and insulators . . . . .	181
9.6.1	The electroscope . . . . .	182
9.7	Attraction between charged and uncharged objects . . . . .	183
9.7.1	Polarisation of Insulators . . . . .	183
9.8	Summary . . . . .	184
9.9	End of chapter exercise . . . . .	184
<b>10</b>	<b>Electric Circuits - Grade 10</b>	<b>187</b>
10.1	Electric Circuits . . . . .	187
10.1.1	Closed circuits . . . . .	187
10.1.2	Representing electric circuits . . . . .	188
10.2	Potential Difference . . . . .	192
10.2.1	Potential Difference . . . . .	192
10.2.2	Potential Difference and Parallel Resistors . . . . .	193
10.2.3	Potential Difference and Series Resistors . . . . .	194
10.2.4	Ohm's Law . . . . .	194



10.2.5 EMF . . . . .	195
10.3 Current . . . . .	198
10.3.1 Flow of Charge . . . . .	198
10.3.2 Current . . . . .	198
10.3.3 Series Circuits . . . . .	199
10.3.4 Parallel Circuits . . . . .	200
10.4 Resistance . . . . .	202
10.4.1 What causes resistance? . . . . .	202
10.4.2 Resistors in electric circuits . . . . .	202
10.5 Instruments to Measure voltage, current and resistance . . . . .	204
10.5.1 Voltmeter . . . . .	204
10.5.2 Ammeter . . . . .	204
10.5.3 Ohmmeter . . . . .	204
10.5.4 Meters Impact on Circuit . . . . .	205
10.6 Exercises - Electric circuits . . . . .	205
<b>III Grade 11 - Physics</b>	<b>209</b>
<b>11 Vectors</b>	<b>211</b>
11.1 Introduction . . . . .	211
11.2 Scalars and Vectors . . . . .	211
11.3 Notation . . . . .	211
11.3.1 Mathematical Representation . . . . .	212
11.3.2 Graphical Representation . . . . .	212
11.4 Directions . . . . .	212
11.4.1 Relative Directions . . . . .	212
11.4.2 Compass Directions . . . . .	213
11.4.3 Bearing . . . . .	213
11.5 Drawing Vectors . . . . .	214
11.6 Mathematical Properties of Vectors . . . . .	215
11.6.1 Adding Vectors . . . . .	215
11.6.2 Subtracting Vectors . . . . .	217
11.6.3 Scalar Multiplication . . . . .	218
11.7 Techniques of Vector Addition . . . . .	218
11.7.1 Graphical Techniques . . . . .	218
11.7.2 Algebraic Addition and Subtraction of Vectors . . . . .	223
11.8 Components of Vectors . . . . .	228
11.8.1 Vector addition using components . . . . .	231
11.8.2 Summary . . . . .	235
11.8.3 End of chapter exercises: Vectors . . . . .	236
11.8.4 End of chapter exercises: Vectors - Long questions . . . . .	237

<b>12 Force, Momentum and Impulse - Grade 11</b>	<b>239</b>
12.1 Introduction . . . . .	239
12.2 Force . . . . .	239
12.2.1 What is a <i>force</i> ? . . . . .	239
12.2.2 Examples of Forces in Physics . . . . .	240
12.2.3 Systems and External Forces . . . . .	241
12.2.4 Force Diagrams . . . . .	242
12.2.5 Free Body Diagrams . . . . .	243
12.2.6 Finding the Resultant Force . . . . .	244
12.2.7 Exercise . . . . .	246
12.3 Newton's Laws . . . . .	246
12.3.1 Newton's First Law . . . . .	247
12.3.2 Newton's Second Law of Motion . . . . .	249
12.3.3 Exercise . . . . .	261
12.3.4 Newton's Third Law of Motion . . . . .	263
12.3.5 Exercise . . . . .	267
12.3.6 Different types of forces . . . . .	268
12.3.7 Exercise . . . . .	275
12.3.8 Forces in equilibrium . . . . .	276
12.3.9 Exercise . . . . .	279
12.4 Forces between Masses . . . . .	282
12.4.1 Newton's Law of Universal Gravitation . . . . .	282
12.4.2 Comparative Problems . . . . .	284
12.4.3 Exercise . . . . .	286
12.5 Momentum and Impulse . . . . .	287
12.5.1 Vector Nature of Momentum . . . . .	290
12.5.2 Exercise . . . . .	291
12.5.3 Change in Momentum . . . . .	291
12.5.4 Exercise . . . . .	293
12.5.5 Newton's Second Law revisited . . . . .	293
12.5.6 Impulse . . . . .	294
12.5.7 Exercise . . . . .	296
12.5.8 Conservation of Momentum . . . . .	297
12.5.9 Physics in Action: Impulse . . . . .	300
12.5.10 Exercise . . . . .	301
12.6 Torque and Levers . . . . .	302
12.6.1 Torque . . . . .	302
12.6.2 Mechanical Advantage and Levers . . . . .	305
12.6.3 Classes of levers . . . . .	307
12.6.4 Exercise . . . . .	308
12.7 Summary . . . . .	309
12.8 End of Chapter exercises . . . . .	310

<b>13 Geometrical Optics - Grade 11</b>	<b>327</b>
13.1 Introduction . . . . .	327
13.2 Lenses . . . . .	327
13.2.1 Converging Lenses . . . . .	329
13.2.2 Diverging Lenses . . . . .	340
13.2.3 Summary of Image Properties . . . . .	343
13.3 The Human Eye . . . . .	344
13.3.1 Structure of the Eye . . . . .	345
13.3.2 Defects of Vision . . . . .	346
13.4 Gravitational Lenses . . . . .	347
13.5 Telescopes . . . . .	347
13.5.1 Refracting Telescopes . . . . .	347
13.5.2 Reflecting Telescopes . . . . .	348
13.5.3 Southern African Large Telescope . . . . .	348
13.6 Microscopes . . . . .	349
13.7 Summary . . . . .	351
13.8 Exercises . . . . .	352
<b>14 Longitudinal Waves - Grade 11</b>	<b>355</b>
14.1 Introduction . . . . .	355
14.2 What is a <i>longitudinal wave</i> ? . . . . .	355
14.3 Characteristics of Longitudinal Waves . . . . .	356
14.3.1 Compression and Rarefaction . . . . .	356
14.3.2 Wavelength and Amplitude . . . . .	357
14.3.3 Period and Frequency . . . . .	357
14.3.4 Speed of a Longitudinal Wave . . . . .	358
14.4 Graphs of Particle Position, Displacement, Velocity and Acceleration . . . . .	359
14.5 Sound Waves . . . . .	360
14.6 Seismic Waves . . . . .	361
14.7 Summary - Longitudinal Waves . . . . .	361
14.8 Exercises - Longitudinal Waves . . . . .	362
<b>15 Sound - Grade 11</b>	<b>363</b>
15.1 Introduction . . . . .	363
15.2 Characteristics of a Sound Wave . . . . .	363
15.2.1 Pitch . . . . .	364
15.2.2 Loudness . . . . .	364
15.2.3 Tone . . . . .	364
15.3 Speed of Sound . . . . .	365
15.4 Physics of the Ear and Hearing . . . . .	365
15.4.1 Intensity of Sound . . . . .	366
15.5 Ultrasound . . . . .	367

15.6 SONAR . . . . .	368
15.6.1 Echolocation . . . . .	368
15.7 Summary . . . . .	369
15.8 Exercises . . . . .	369
<b>16 The Physics of Music - Grade 11</b>	<b>373</b>
16.1 Introduction . . . . .	373
16.2 Standing Waves in String Instruments . . . . .	373
16.3 Standing Waves in Wind Instruments . . . . .	377
16.4 Resonance . . . . .	382
16.5 Music and Sound Quality . . . . .	384
16.6 Summary - The Physics of Music . . . . .	385
16.7 End of Chapter Exercises . . . . .	386
<b>17 Electrostatics - Grade 11</b>	<b>387</b>
17.1 Introduction . . . . .	387
17.2 Forces between charges - Coulomb's Law . . . . .	387
17.3 Electric field around charges . . . . .	392
17.3.1 Electric field lines . . . . .	393
17.3.2 Positive charge acting on a test charge . . . . .	393
17.3.3 Combined charge distributions . . . . .	394
17.3.4 Parallel plates . . . . .	397
17.4 Electrical potential energy and potential . . . . .	400
17.4.1 Electrical potential . . . . .	400
17.4.2 Real-world application: lightning . . . . .	402
17.5 Capacitance and the parallel plate capacitor . . . . .	403
17.5.1 Capacitors and capacitance . . . . .	403
17.5.2 Dielectrics . . . . .	404
17.5.3 Physical properties of the capacitor and capacitance . . . . .	404
17.5.4 Electric field in a capacitor . . . . .	405
17.6 Capacitor as a circuit device . . . . .	406
17.6.1 A capacitor in a circuit . . . . .	406
17.6.2 Real-world applications: capacitors . . . . .	407
17.7 Summary . . . . .	407
17.8 Exercises - Electrostatics . . . . .	407
<b>18 Electromagnetism - Grade 11</b>	<b>413</b>
18.1 Introduction . . . . .	413
18.2 Magnetic field associated with a current . . . . .	413
18.2.1 Real-world applications . . . . .	418
18.3 Current induced by a changing magnetic field . . . . .	420
18.3.1 Real-life applications . . . . .	422
18.4 Transformers . . . . .	423

18.4.1 Real-world applications . . . . .	425
18.5 Motion of a charged particle in a magnetic field . . . . .	425
18.5.1 Real-world applications . . . . .	426
18.6 Summary . . . . .	427
18.7 End of chapter exercises . . . . .	427
<b>19 Electric Circuits - Grade 11</b>	<b>429</b>
19.1 Introduction . . . . .	429
19.2 Ohm's Law . . . . .	429
19.2.1 Definition of Ohm's Law . . . . .	429
19.2.2 Ohmic and non-ohmic conductors . . . . .	431
19.2.3 Using Ohm's Law . . . . .	432
19.3 Resistance . . . . .	433
19.3.1 Equivalent resistance . . . . .	433
19.3.2 Use of Ohm's Law in series and parallel Circuits . . . . .	438
19.3.3 Batteries and internal resistance . . . . .	440
19.4 Series and parallel networks of resistors . . . . .	442
19.5 Wheatstone bridge . . . . .	445
19.6 Summary . . . . .	447
19.7 End of chapter exercise . . . . .	447
<b>20 Electronic Properties of Matter - Grade 11</b>	<b>451</b>
20.1 Introduction . . . . .	451
20.2 Conduction . . . . .	451
20.2.1 Metals . . . . .	453
20.2.2 Insulator . . . . .	453
20.2.3 Semi-conductors . . . . .	454
20.3 Intrinsic Properties and Doping . . . . .	454
20.3.1 Surplus . . . . .	455
20.3.2 Deficiency . . . . .	455
20.4 The p-n junction . . . . .	457
20.4.1 Differences between p- and n-type semi-conductors . . . . .	457
20.4.2 The p-n Junction . . . . .	457
20.4.3 Unbiased . . . . .	457
20.4.4 Forward biased . . . . .	457
20.4.5 Reverse biased . . . . .	458
20.4.6 Real-World Applications of Semiconductors . . . . .	458
20.5 End of Chapter Exercises . . . . .	459
<b>IV Grade 12 - Physics</b>	<b>461</b>
<b>21 Motion in Two Dimensions - Grade 12</b>	<b>463</b>
21.1 Introduction . . . . .	463

21.2 Vertical Projectile Motion . . . . .	463
21.2.1 Motion in a Gravitational Field . . . . .	463
21.2.2 Equations of Motion . . . . .	464
21.2.3 Graphs of Vertical Projectile Motion . . . . .	467
21.3 Conservation of Momentum in Two Dimensions . . . . .	475
21.4 Types of Collisions . . . . .	480
21.4.1 Elastic Collisions . . . . .	480
21.4.2 Inelastic Collisions . . . . .	485
21.5 Frames of Reference . . . . .	490
21.5.1 Introduction . . . . .	490
21.5.2 What is a <i>frame of reference</i> ? . . . . .	491
21.5.3 Why are frames of reference important? . . . . .	491
21.5.4 Relative Velocity . . . . .	491
21.6 Summary . . . . .	494
21.7 End of chapter exercises . . . . .	495
<b>22 Mechanical Properties of Matter - Grade 12</b>	<b>503</b>
22.1 Introduction . . . . .	503
22.2 Deformation of materials . . . . .	503
22.2.1 Hooke's Law . . . . .	503
22.2.2 Deviation from Hooke's Law . . . . .	506
22.3 Elasticity, plasticity, fracture, creep . . . . .	508
22.3.1 Elasticity and plasticity . . . . .	508
22.3.2 Fracture, creep and fatigue . . . . .	508
22.4 Failure and strength of materials . . . . .	509
22.4.1 The properties of matter . . . . .	509
22.4.2 Structure and failure of materials . . . . .	509
22.4.3 Controlling the properties of materials . . . . .	509
22.4.4 Steps of Roman Swordsmithing . . . . .	510
22.5 Summary . . . . .	511
22.6 End of chapter exercise . . . . .	511
<b>23 Work, Energy and Power - Grade 12</b>	<b>513</b>
23.1 Introduction . . . . .	513
23.2 Work . . . . .	513
23.3 Energy . . . . .	519
23.3.1 External and Internal Forces . . . . .	519
23.3.2 Capacity to do Work . . . . .	520
23.4 Power . . . . .	525
23.5 Important Equations and Quantities . . . . .	529
23.6 End of Chapter Exercises . . . . .	529

<b>24 Doppler Effect - Grade 12</b>	<b>533</b>
24.1 Introduction . . . . .	533
24.2 The Doppler Effect with Sound and Ultrasound . . . . .	533
24.2.1 Ultrasound and the Doppler Effect . . . . .	537
24.3 The Doppler Effect with Light . . . . .	537
24.3.1 The Expanding Universe . . . . .	538
24.4 Summary . . . . .	539
24.5 End of Chapter Exercises . . . . .	539
<b>25 Colour - Grade 12</b>	<b>541</b>
25.1 Introduction . . . . .	541
25.2 Colour and Light . . . . .	541
25.2.1 Dispersion of white light . . . . .	544
25.3 Addition and Subtraction of Light . . . . .	544
25.3.1 Additive Primary Colours . . . . .	544
25.3.2 Subtractive Primary Colours . . . . .	545
25.3.3 Complementary Colours . . . . .	546
25.3.4 Perception of Colour . . . . .	546
25.3.5 Colours on a Television Screen . . . . .	547
25.4 Pigments and Paints . . . . .	548
25.4.1 Colour of opaque objects . . . . .	548
25.4.2 Colour of transparent objects . . . . .	548
25.4.3 Pigment primary colours . . . . .	549
25.5 End of Chapter Exercises . . . . .	550
<b>26 2D and 3D Wavefronts - Grade 12</b>	<b>553</b>
26.1 Introduction . . . . .	553
26.2 Wavefronts . . . . .	553
26.3 The Huygens Principle . . . . .	554
26.4 Interference . . . . .	556
26.5 Diffraction . . . . .	557
26.5.1 Diffraction through a Slit . . . . .	558
26.6 Shock Waves and Sonic Booms . . . . .	562
26.6.1 Subsonic Flight . . . . .	563
26.6.2 Supersonic Flight . . . . .	563
26.6.3 Mach Cone . . . . .	566
26.7 End of Chapter Exercises . . . . .	568
<b>27 Wave Nature of Matter - Grade 12</b>	<b>571</b>
27.1 Introduction . . . . .	571
27.2 de Broglie Wavelength . . . . .	571
27.3 The Electron Microscope . . . . .	574
27.3.1 Disadvantages of an Electron Microscope . . . . .	577

27.3.2	Uses of Electron Microscopes . . . . .	577
27.4	End of Chapter Exercises . . . . .	578
<b>28</b>	<b>Electrodynamics - Grade 12</b>	<b>579</b>
28.1	Introduction . . . . .	579
28.2	Electrical machines - generators and motors . . . . .	579
28.2.1	Electrical generators . . . . .	580
28.2.2	Electric motors . . . . .	582
28.2.3	Real-life applications . . . . .	582
28.2.4	Exercise - generators and motors . . . . .	584
28.3	Alternating Current . . . . .	585
28.3.1	Exercise - alternating current . . . . .	586
28.4	Capacitance and inductance . . . . .	586
28.4.1	Capacitance . . . . .	586
28.4.2	Inductance . . . . .	586
28.4.3	Exercise - capacitance and inductance . . . . .	588
28.5	Summary . . . . .	588
28.6	End of chapter exercise . . . . .	589
<b>29</b>	<b>Electronics - Grade 12</b>	<b>591</b>
29.1	Introduction . . . . .	591
29.2	Capacitive and Inductive Circuits . . . . .	591
29.3	Filters and Signal Tuning . . . . .	596
29.3.1	Capacitors and Inductors as Filters . . . . .	596
29.3.2	LRC Circuits, Resonance and Signal Tuning . . . . .	596
29.4	Active Circuit Elements . . . . .	599
29.4.1	The Diode . . . . .	599
29.4.2	The Light Emitting Diode (LED) . . . . .	601
29.4.3	Transistor . . . . .	603
29.4.4	The Operational Amplifier . . . . .	607
29.5	The Principles of Digital Electronics . . . . .	609
29.5.1	Logic Gates . . . . .	610
29.6	Using and Storing Binary Numbers . . . . .	616
29.6.1	Binary numbers . . . . .	616
29.6.2	Counting circuits . . . . .	617
29.6.3	Storing binary numbers . . . . .	619
<b>30</b>	<b>EM Radiation</b>	<b>625</b>
30.1	Introduction . . . . .	625
30.2	Particle/wave nature of electromagnetic radiation . . . . .	625
30.3	The wave nature of electromagnetic radiation . . . . .	626
30.4	Electromagnetic spectrum . . . . .	626
30.5	The particle nature of electromagnetic radiation . . . . .	629



30.5.1 Exercise - particle nature of EM waves . . . . .	630
30.6 Penetrating ability of electromagnetic radiation . . . . .	631
30.6.1 Ultraviolet(UV) radiation and the skin . . . . .	631
30.6.2 Ultraviolet radiation and the eyes . . . . .	632
30.6.3 X-rays . . . . .	632
30.6.4 Gamma-rays . . . . .	632
30.6.5 Exercise - Penetrating ability of EM radiation . . . . .	633
30.7 Summary . . . . .	633
30.8 End of chapter exercise . . . . .	633
<b>31 Optical Phenomena and Properties of Matter - Grade 12</b>	<b>635</b>
31.1 Introduction . . . . .	635
31.2 The transmission and scattering of light . . . . .	635
31.2.1 Energy levels of an electron . . . . .	635
31.2.2 Interaction of light with metals . . . . .	636
31.2.3 Why is the sky blue? . . . . .	637
31.3 The photoelectric effect . . . . .	638
31.3.1 Applications of the photoelectric effect . . . . .	640
31.3.2 Real-life applications . . . . .	642
31.4 Emission and absorption spectra . . . . .	643
31.4.1 Emission Spectra . . . . .	643
31.4.2 Absorption spectra . . . . .	644
31.4.3 Colours and energies of electromagnetic radiation . . . . .	646
31.4.4 Applications of emission and absorption spectra . . . . .	648
31.5 Lasers . . . . .	650
31.5.1 How a laser works . . . . .	652
31.5.2 A simple laser . . . . .	654
31.5.3 Laser applications and safety . . . . .	655
31.6 Summary . . . . .	656
31.7 End of chapter exercise . . . . .	657
<b>V Exercises</b>	<b>659</b>
<b>32 Exercises</b>	<b>661</b>
<b>VI Essays</b>	<b>663</b>
<b>Essay 1: Energy and electricity. Why the fuss?</b>	<b>665</b>
<b>33 Essay: How a cell phone works</b>	<b>671</b>
<b>34 Essay: How a Physiotherapist uses the Concept of Levers</b>	<b>673</b>
<b>35 Essay: How a Pilot Uses Vectors</b>	<b>675</b>

**A GNU Free Documentation License**

**677**

## Chapter 20

# Electronic Properties of Matter - Grade 11

### 20.1 Introduction

We can study many different features of solids. Just a few of the things we could study are how hard or soft they are, what are their magnetic properties or how well do they conduct heat. The thing that we are interested in, in this chapter are their electronic properties. Simply how well do they conduct electricity and how do they do it.

We are only going to discuss materials that form a 3-dimensional lattice. This means that the atoms that make up the material have a regular pattern (carbon, silicon, etc.). We won't discuss materials where the atoms are jumbled together in an irregular way (plastic, glass, rubber etc.).

### 20.2 Conduction

We know that there are materials that do conduct electricity, called conductors, like the copper wires in the circuits you build. There are also materials that do not conduct electricity, called insulators, like the plastic covering on the copper wires.

Conductors come in two major categories: metals (e.g. copper) and semi-conductors (e.g. silicon). Metals conduct very well and semi-conductors don't. One very interesting difference is that metals conduct less as they become hotter but semi-conductors conduct more.

What is different about these substances that makes them conduct differently? That is what we are about to find out.

We have learnt that electrons in an atom have discrete energy levels. When an electron is given the right amount of energy, it can jump to a higher energy level, while if it loses the right amount of energy it can drop to a lower energy level. The lowest energy level is known as the ground state.

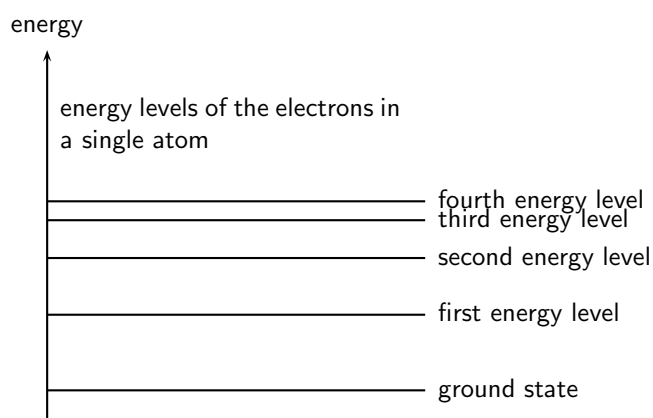

When two atoms are far apart from each other they don't influence each other. Look at the picture below. There are two atoms depicted by the black dots. When they are far apart their electron clouds (the gray clouds) are distinct. The dotted line depicts the distance of the outermost electron energy level that is occupied.

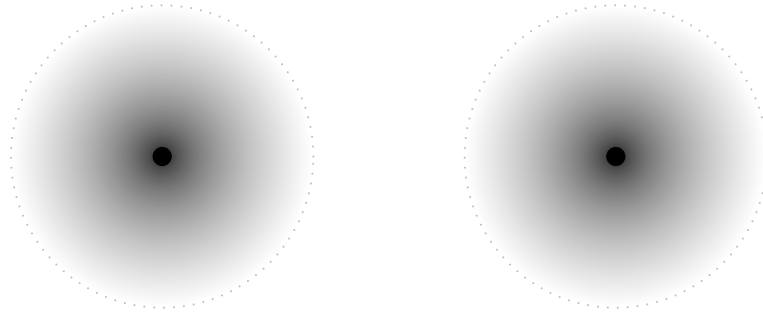

In some lattice structures the atoms would be closer together. If they are close enough their electron clouds, and therefore electron energy levels start to overlap. Look at the picture below. In this picture the two atoms are closer together. The electron clouds now overlap. The overlapping area is coloured in solid gray to make it easier to see.

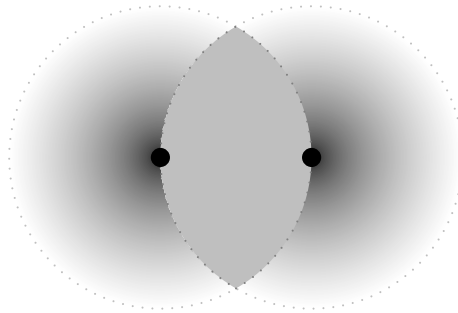

When this happens we might find two electrons with the same energy and spin in the same space. We know that this is not allowed from the Pauli exclusion principle. Something must change to allow the overlapping to happen. The change is that the energies of the energy levels change a tiny bit so that the electrons are not in exactly the same spin and energy state at the same time.

So if we have 2 atoms then in the overlapping area we will have twice the number of electrons and energy levels but the energy levels from the different atoms will be very very close in energy. If we had 3 atoms then there would be 3 energy levels very close in energy and so on. In a solid there may be very many energy levels that are very close in energy. These groups of energy levels are called bands. The spacing between these bands determines whether the solid is a conductor or an insulator.

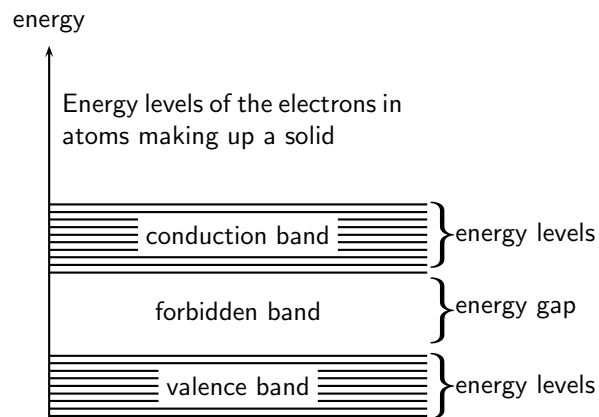

In a gas, the atoms are spaced far apart and they do not influence each other. However, the atoms in a solid greatly influence each other. The forces that bind these atoms together in a

solid affect how the electrons of the atoms behave, by causing the individual energy levels of an atom to break up and form energy bands. The resulting energy levels are more closely spaced than those in the individual atoms. The energy bands still contain discrete energy levels, but there are now many more energy levels than in the single atom.

In crystalline solids, atoms interact with their neighbors, and the energy levels of the electrons in isolated atoms turn into bands. Whether a material conducts or not is determined by its band structure.

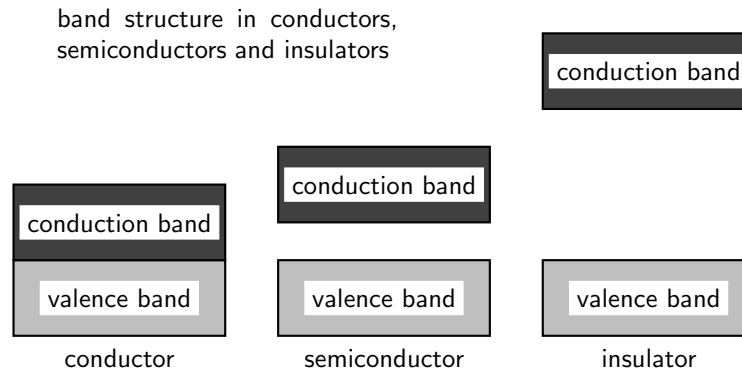

Electrons follow the Pauli exclusion principle, meaning that two electrons cannot occupy the same state. Thus electrons in a solid fill up the energy bands up to a certain level (this is called the Fermi energy). Bands which are completely full of electrons cannot conduct electricity, because there is no state of nearby energy to which the electrons can jump. Materials in which all bands are full are insulators.

### 20.2.1 Metals

Metals are good conductors because they have unfilled space in the valence energy band. In the absence of an electric field, there are electrons traveling in all directions. When an electric field is applied the mobile electrons flow. Electrons in this band can be accelerated by the electric field because there are plenty of nearby unfilled states in the band.

### 20.2.2 Insulator

The energy diagram for the insulator shows the insulator with a very wide energy gap. The wider this gap, the greater the amount of energy required to move the electron from the valence band to the conduction band. Therefore, an insulator requires a large amount of energy to obtain a small amount of current. The insulator “insulates” because of the wide forbidden band or energy gap.

#### Breakdown

A solid with filled bands is an insulator. If we raise the temperature the electrons gain thermal energy. If there is enough energy added then electrons can be thermally excited from the valence band to the conduction band. The fraction of electrons excited in this way depends on:

- the temperature and
- the band gap, the energy difference between the two bands.

Exciting these electrons into the conduction band leaves behind positively charged holes in the valence band, which can also conduct electricity.

### 20.2.3 Semi-conductors

A semi-conductor is very similar to an insulator. The main difference between semiconductors and insulators is the size of the band gap between the conduction and valence bands. The band gap in insulators is larger than the band gap in semiconductors.

In semi-conductors at room temperature, just as in insulators, very few electrons gain enough thermal energy to leap the band gap, which is necessary for conduction. For this reason, pure semi-conductors and insulators, in the absence of applied fields, have roughly similar electrical properties. The smaller band gaps of semi-conductors, however, allow for many other means besides temperature to control their electrical properties. The most important one being that for a certain amount of applied voltage, more current will flow in the semiconductor than in the insulator.



---

#### Exercise: Conduction

1. Explain how energy levels of electrons in an atom combine with those of other atoms in the formation of crystals.
  2. Explain how the resulting energy levels are more closely spaced than those in the individual atoms, forming energy bands.
  3. Explain the existence of energy bands in metal crystals as the result of superposition of energy levels.
  4. Explain and contrast the conductivity of conductors, semi-conductors and insulators using energy band theory.
  5. What is the main difference in the energy arrangement between an isolated atom and the atom in a solid?
  6. What determines whether a solid is an insulator, a semiconductor, or a conductor?
- 

## 20.3 Intrinsic Properties and Doping

We have seen that the size of the energy gap between the valence band and the conduction band determines whether a solid is a conductor or an insulator. However, we have seen that there is a material known as a semi-conductor. A semi-conductor is a solid whose band gap is smaller than that of an insulator and whose electrical properties can be modified by a process known as *doping*.



#### Definition: Doping

Doping is the deliberate addition of impurities to a pure semiconductor material to change its electrical properties.

Semiconductors are often the Group IV elements in the periodic table. The most common semiconductor elements are silicon (Si) and germanium (Ge). The most important property of Group IV elements is that they have 4 valence electrons.



#### Extension: Band Gaps of Si and Ge

Si has a band gap of  $1.744 \times 10^{-19}$  J while Ge has a band gap of  $1.152 \times 10^{-19}$  J.

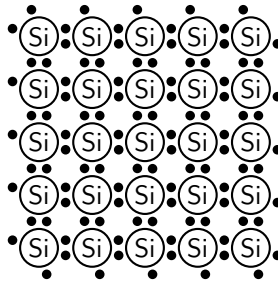

Figure 20.1: Arrangement of atoms in a Si crystal.

So, if we look at the arrangement of for example Si atoms in a crystal, they would look like that shown in Figure 20.1.

The main aim of doping is to make sure there are either too many (surplus) or too few electrons (deficiency). Depending on what situation you want to create you use different elements for the doping.

### 20.3.1 Surplus

A surplus of electrons is created by adding an element that has more valence electrons than Si to the Si crystal. This is known as *n-type* doping and elements used for n-type doping usually come from Group V in the periodic table. Elements from Group V have 5 valence electrons, one more than the Group IV elements.

A common n-type dopant (substance used for doping) is arsenic (As). The combination of a semiconductor and an n-type dopant is known as an n-type semiconductor. A Si crystal doped with As is shown in Figure 20.2. When As is added to a Si crystal, the 4 of the 5 valence electrons in As bond with the 4 Si valence electrons. The fifth As valence electron is free to move around.

It takes only a few As atoms to create enough free electrons to allow an electric current to flow through the silicon. Since n-type dopants 'donate' their free atoms to the semiconductor, they are known as *donor atoms*.

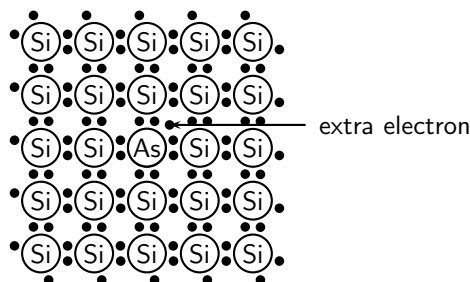

Figure 20.2: Si crystal doped with As. For each As atom present in the Si crystal, there is one extra electron. This combination of Si and As is known as an n-type semiconductor, because of its overall surplus of electrons.

### 20.3.2 Deficiency

A deficiency of electrons is created by adding an element that has less valence electrons than Si to the Si crystal. This is known as *p-type* doping and elements used for p-type doping usually come from Group III in the periodic table. Elements from Group III have 3 valence electrons, one less than the semiconductor elements that come from Group IV. A common p-type dopant is boron (B). The combination of a semiconductor and a p-type dopant is known as an p-type semiconductor. A Si crystal doped with B is shown in Figure 20.3. When B is mixed into the silicon crystal, there is a Si valence electron that is left unbonded.

The lack of an electron is known as a *hole* and has the effect of a positive charge. Holes can conduct current. A hole happily accepts an electron from a neighbor, moving the hole over a space. Since p-type dopants 'accept' electrons, they are known as *acceptor atoms*.

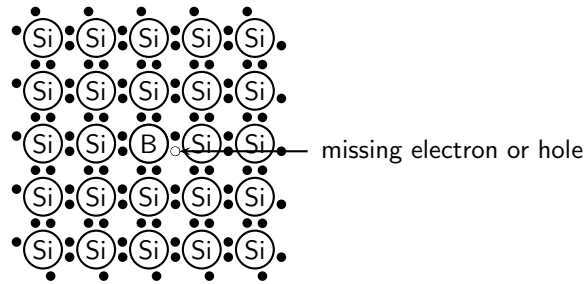
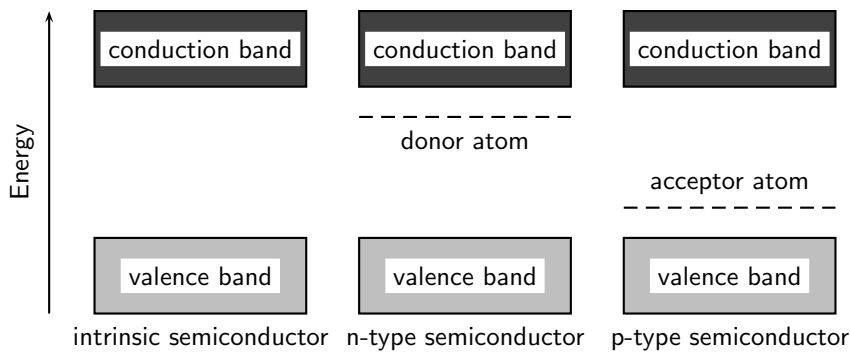

Figure 20.3: Si crystal doped with B. For each B atom present in the Si crystal, there is one less electron. This combination of Si and B is known as a p-type semiconductor, because of its overall deficiency of electrons.

Donor (n-type) impurities have extra valence electrons with energies very close to the conduction band which can be easily thermally excited to the conduction band. Acceptor (p-type) impurities capture electrons from the valence band, allowing the easy formation of holes.



The energy level of the donor atom is close to the conduction band and it is relatively easy for electrons to enter the conduction band. The energy level of the acceptor atom is close to the valence band and it is relatively easy for electrons to leave the valence band and enter the vacancies left by the holes.



### Exercise: Intrinsic Properties and Doping

1. Explain the process of doping using detailed diagrams for p-type and n-type semiconductors.
2. Draw a diagram showing a Ge crystal doped with As. What type of semiconductor is this?
3. Draw a diagram showing a Ge crystal doped with B. What type of semiconductor is this?
4. Explain how doping improves the conductivity of semi-conductors.
5. Would the following elements make good p-type dopants or good n-type dopants?
  - A B
  - B P
  - C Ga
  - D As



E In  
F Bi

---

## 20.4 The p-n junction

### 20.4.1 Differences between p- and n-type semi-conductors

We have seen that the addition of specific elements to semiconductor materials turns them into p-type semiconductors or n-type semiconductors. The differences between n- and p-type semiconductors are summarised in Table ??.

### 20.4.2 The p-n Junction

When p-type and n-type semiconductors are placed in contact with each other, a p-n junction is formed. Near the junction, electrons and holes combine to create a depletion region.

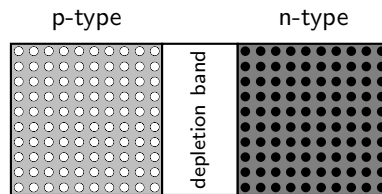

Figure 20.4: The p-n junction forms between p- and n-type semiconductors. The free electrons from the n-type material combine with the holes in the p-type material near the junction. There is a small potential difference across the junction. The area near the junction is called the depletion region because there are few holes and few free electrons in this region.

Electric current flows more easily across a p-n junction in one direction than in the other. If the positive pole of a battery is connected to the p-side of the junction, and the negative pole to the n-side, charge flows across the junction. If the battery is connected in the opposite direction, very little charge can flow.

This might not sound very useful at first but the p-n junction forms the basis for computer chips, solar cells, and other electronic devices.

### 20.4.3 Unbiased

In a p-n junction, without an external applied voltage (no bias), an equilibrium condition is reached in which a potential difference is formed across the junction.

P-type is where you have more "holes"; N-type is where you have more electrons in the material. Initially, when you put them together to form a junction, holes near the junction tends to "move" across to the N-region, while the electrons in the N-region drift across to the p-region to "fill" some holes. This current will quickly stop as the potential barrier is built up by the migrated charges. So in steady state no current flows.

Then now when you put a potential different across the terminals you have two cases: forward biased and reverse biased.

### 20.4.4 Forward biased

Forward-bias occurs when the p-type semiconductor material is connected to the positive terminal of a battery and the n-type semiconductor material is connected to the negative terminal.

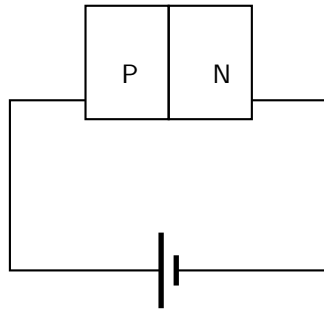

The electric field from the external potential difference can easily overcome the small internal field (in the so-called depletion region, created by the initial drifting of charges): usually anything bigger than 0.6V would be enough. The external field then attracts more  $e^-$  to flow from n-region to p-region and more holes from p-region to n-region and you have a forward biased situation. the diode is ON.

#### 20.4.5 Reverse biased

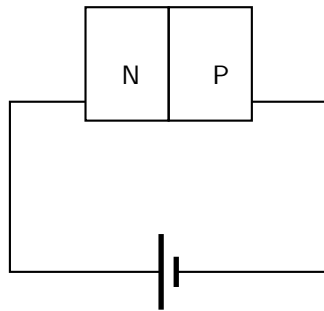

in this case the external field pushes  $e^-$  back to the n-region while more holes into the p-region, as a result you get no current flow. Only the small number of thermally released minority carriers (holes in the n-type region and  $e^-$  in the p-type region) will be able to cross the junction and form a very small current, but for all practical purposes, this can be ignored

of course if the reverse biased potential is large enough you get avalanche break down and current flow in the opposite direction. In many cases, except for Zener diodes, you most likely will destroy the diode.

#### 20.4.6 Real-World Applications of Semiconductors

Semiconductors form the basis of modern electronics. Every electrical appliance usually has some semiconductor-based technology inside it. The fundamental uses of semiconductors are in microchips (also known as integrated circuits) and microprocessors.

Integrated circuits are miniaturised circuits. The use of integrated circuits makes it possible for electronic devices (like a cellular telephone or a hi-fi) to get smaller.

Microprocessors are a special type of integrated circuit. (NOTE TO SELF: more is needed but I'm not that knowledgeable and I'm tired of Googling...)

---

#### Activity :: Research Project : Semiconductors

Assess the impact on society of the invention of transistors, with particular reference to their use in microchips (integrated circuits) and microprocessors.



---

**Exercise: The p-n junction**

1. Compare p- and n-type semi-conductors.
  2. Explain how a p-n junction works using a diagram.
  3. Give everyday examples of the application.
- 

## 20.5 End of Chapter Exercises

1. What is a conductor?
2. What is an insulator?
3. What is a semiconductor?



# Appendix A

## GNU Free Documentation License

Version 1.2, November 2002

Copyright © 2000,2001,2002 Free Software Foundation, Inc.

59 Temple Place, Suite 330, Boston, MA 02111-1307 USA

Everyone is permitted to copy and distribute verbatim copies of this license document, but changing it is not allowed.

### PREAMBLE

The purpose of this License is to make a manual, textbook, or other functional and useful document “free” in the sense of freedom: to assure everyone the effective freedom to copy and redistribute it, with or without modifying it, either commercially or non-commercially. Secondly, this License preserves for the author and publisher a way to get credit for their work, while not being considered responsible for modifications made by others.

This License is a kind of “copyleft”, which means that derivative works of the document must themselves be free in the same sense. It complements the GNU General Public License, which is a copyleft license designed for free software.

We have designed this License in order to use it for manuals for free software, because free software needs free documentation: a free program should come with manuals providing the same freedoms that the software does. But this License is not limited to software manuals; it can be used for any textual work, regardless of subject matter or whether it is published as a printed book. We recommend this License principally for works whose purpose is instruction or reference.

### APPLICABILITY AND DEFINITIONS

This License applies to any manual or other work, in any medium, that contains a notice placed by the copyright holder saying it can be distributed under the terms of this License. Such a notice grants a world-wide, royalty-free license, unlimited in duration, to use that work under the conditions stated herein. The “Document”, below, refers to any such manual or work. Any member of the public is a licensee, and is addressed as “you”. You accept the license if you copy, modify or distribute the work in a way requiring permission under copyright law.

A “Modified Version” of the Document means any work containing the Document or a portion of it, either copied verbatim, or with modifications and/or translated into another language.

A “Secondary Section” is a named appendix or a front-matter section of the Document that deals exclusively with the relationship of the publishers or authors of the Document to the Document’s overall subject (or to related matters) and contains nothing that could fall directly within that overall subject. (Thus, if the Document is in part a textbook of mathematics, a

Secondary Section may not explain any mathematics.) The relationship could be a matter of historical connection with the subject or with related matters, or of legal, commercial, philosophical, ethical or political position regarding them.

The “Invariant Sections” are certain Secondary Sections whose titles are designated, as being those of Invariant Sections, in the notice that says that the Document is released under this License. If a section does not fit the above definition of Secondary then it is not allowed to be designated as Invariant. The Document may contain zero Invariant Sections. If the Document does not identify any Invariant Sections then there are none.

The “Cover Texts” are certain short passages of text that are listed, as Front-Cover Texts or Back-Cover Texts, in the notice that says that the Document is released under this License. A Front-Cover Text may be at most 5 words, and a Back-Cover Text may be at most 25 words.

A “Transparent” copy of the Document means a machine-readable copy, represented in a format whose specification is available to the general public, that is suitable for revising the document straightforwardly with generic text editors or (for images composed of pixels) generic paint programs or (for drawings) some widely available drawing editor, and that is suitable for input to text formatters or for automatic translation to a variety of formats suitable for input to text formatters. A copy made in an otherwise Transparent file format whose markup, or absence of markup, has been arranged to thwart or discourage subsequent modification by readers is not Transparent. An image format is not Transparent if used for any substantial amount of text. A copy that is not “Transparent” is called “Opaque”.

Examples of suitable formats for Transparent copies include plain ASCII without markup, Texinfo input format,  $\LaTeX$  input format, SGML or XML using a publicly available DTD and standard-conforming simple HTML, PostScript or PDF designed for human modification. Examples of transparent image formats include PNG, XCF and JPG. Opaque formats include proprietary formats that can be read and edited only by proprietary word processors, SGML or XML for which the DTD and/or processing tools are not generally available, and the machine-generated HTML, PostScript or PDF produced by some word processors for output purposes only.

The “Title Page” means, for a printed book, the title page itself, plus such following pages as are needed to hold, legibly, the material this License requires to appear in the title page. For works in formats which do not have any title page as such, “Title Page” means the text near the most prominent appearance of the work’s title, preceding the beginning of the body of the text.

A section “Entitled XYZ” means a named subunit of the Document whose title either is precisely XYZ or contains XYZ in parentheses following text that translates XYZ in another language. (Here XYZ stands for a specific section name mentioned below, such as “Acknowledgements”, “Dedications”, “Endorsements”, or “History”.) To “Preserve the Title” of such a section when you modify the Document means that it remains a section “Entitled XYZ” according to this definition.

The Document may include Warranty Disclaimers next to the notice which states that this License applies to the Document. These Warranty Disclaimers are considered to be included by reference in this License, but only as regards disclaiming warranties: any other implication that these Warranty Disclaimers may have is void and has no effect on the meaning of this License.

## VERBATIM COPYING

You may copy and distribute the Document in any medium, either commercially or non-commercially, provided that this License, the copyright notices, and the license notice saying this License applies to the Document are reproduced in all copies, and that you add no other conditions whatsoever to those of this License. You may not use technical measures to obstruct or control the reading or further copying of the copies you make or distribute. However, you may accept compensation in exchange for copies. If you distribute a large enough number of copies you must also follow the conditions in section A.

You may also lend copies, under the same conditions stated above, and you may publicly display copies.

## COPYING IN QUANTITY

If you publish printed copies (or copies in media that commonly have printed covers) of the Document, numbering more than 100, and the Document's license notice requires Cover Texts, you must enclose the copies in covers that carry, clearly and legibly, all these Cover Texts: Front-Cover Texts on the front cover, and Back-Cover Texts on the back cover. Both covers must also clearly and legibly identify you as the publisher of these copies. The front cover must present the full title with all words of the title equally prominent and visible. You may add other material on the covers in addition. Copying with changes limited to the covers, as long as they preserve the title of the Document and satisfy these conditions, can be treated as verbatim copying in other respects.

If the required texts for either cover are too voluminous to fit legibly, you should put the first ones listed (as many as fit reasonably) on the actual cover, and continue the rest onto adjacent pages.

If you publish or distribute Opaque copies of the Document numbering more than 100, you must either include a machine-readable Transparent copy along with each Opaque copy, or state in or with each Opaque copy a computer-network location from which the general network-using public has access to download using public-standard network protocols a complete Transparent copy of the Document, free of added material. If you use the latter option, you must take reasonably prudent steps, when you begin distribution of Opaque copies in quantity, to ensure that this Transparent copy will remain thus accessible at the stated location until at least one year after the last time you distribute an Opaque copy (directly or through your agents or retailers) of that edition to the public.

It is requested, but not required, that you contact the authors of the Document well before redistributing any large number of copies, to give them a chance to provide you with an updated version of the Document.

## MODIFICATIONS

You may copy and distribute a Modified Version of the Document under the conditions of sections A and A above, provided that you release the Modified Version under precisely this License, with the Modified Version filling the role of the Document, thus licensing distribution and modification of the Modified Version to whoever possesses a copy of it. In addition, you must do these things in the Modified Version:

1. Use in the Title Page (and on the covers, if any) a title distinct from that of the Document, and from those of previous versions (which should, if there were any, be listed in the History section of the Document). You may use the same title as a previous version if the original publisher of that version gives permission.
2. List on the Title Page, as authors, one or more persons or entities responsible for authorship of the modifications in the Modified Version, together with at least five of the principal authors of the Document (all of its principal authors, if it has fewer than five), unless they release you from this requirement.
3. State on the Title page the name of the publisher of the Modified Version, as the publisher.
4. Preserve all the copyright notices of the Document.
5. Add an appropriate copyright notice for your modifications adjacent to the other copyright notices.

6. Include, immediately after the copyright notices, a license notice giving the public permission to use the Modified Version under the terms of this License, in the form shown in the Addendum below.
7. Preserve in that license notice the full lists of Invariant Sections and required Cover Texts given in the Document's license notice.
8. Include an unaltered copy of this License.
9. Preserve the section Entitled "History", Preserve its Title, and add to it an item stating at least the title, year, new authors, and publisher of the Modified Version as given on the Title Page. If there is no section Entitled "History" in the Document, create one stating the title, year, authors, and publisher of the Document as given on its Title Page, then add an item describing the Modified Version as stated in the previous sentence.
10. Preserve the network location, if any, given in the Document for public access to a Transparent copy of the Document, and likewise the network locations given in the Document for previous versions it was based on. These may be placed in the "History" section. You may omit a network location for a work that was published at least four years before the Document itself, or if the original publisher of the version it refers to gives permission.
11. For any section Entitled "Acknowledgements" or "Dedications", Preserve the Title of the section, and preserve in the section all the substance and tone of each of the contributor acknowledgements and/or dedications given therein.
12. Preserve all the Invariant Sections of the Document, unaltered in their text and in their titles. Section numbers or the equivalent are not considered part of the section titles.
13. Delete any section Entitled "Endorsements". Such a section may not be included in the Modified Version.
14. Do not re-title any existing section to be Entitled "Endorsements" or to conflict in title with any Invariant Section.
15. Preserve any Warranty Disclaimers.

If the Modified Version includes new front-matter sections or appendices that qualify as Secondary Sections and contain no material copied from the Document, you may at your option designate some or all of these sections as invariant. To do this, add their titles to the list of Invariant Sections in the Modified Version's license notice. These titles must be distinct from any other section titles.

You may add a section Entitled "Endorsements", provided it contains nothing but endorsements of your Modified Version by various parties—for example, statements of peer review or that the text has been approved by an organisation as the authoritative definition of a standard.

You may add a passage of up to five words as a Front-Cover Text, and a passage of up to 25 words as a Back-Cover Text, to the end of the list of Cover Texts in the Modified Version. Only one passage of Front-Cover Text and one of Back-Cover Text may be added by (or through arrangements made by) any one entity. If the Document already includes a cover text for the same cover, previously added by you or by arrangement made by the same entity you are acting on behalf of, you may not add another; but you may replace the old one, on explicit permission from the previous publisher that added the old one.

The author(s) and publisher(s) of the Document do not by this License give permission to use their names for publicity for or to assert or imply endorsement of any Modified Version.

## COMBINING DOCUMENTS

You may combine the Document with other documents released under this License, under the terms defined in section A above for modified versions, provided that you include in the



combination all of the Invariant Sections of all of the original documents, unmodified, and list them all as Invariant Sections of your combined work in its license notice, and that you preserve all their Warranty Disclaimers.

The combined work need only contain one copy of this License, and multiple identical Invariant Sections may be replaced with a single copy. If there are multiple Invariant Sections with the same name but different contents, make the title of each such section unique by adding at the end of it, in parentheses, the name of the original author or publisher of that section if known, or else a unique number. Make the same adjustment to the section titles in the list of Invariant Sections in the license notice of the combined work.

In the combination, you must combine any sections Entitled “History” in the various original documents, forming one section Entitled “History”; likewise combine any sections Entitled “Acknowledgements”, and any sections Entitled “Dedications”. You must delete all sections Entitled “Endorsements”.

## COLLECTIONS OF DOCUMENTS

You may make a collection consisting of the Document and other documents released under this License, and replace the individual copies of this License in the various documents with a single copy that is included in the collection, provided that you follow the rules of this License for verbatim copying of each of the documents in all other respects.

You may extract a single document from such a collection, and distribute it individually under this License, provided you insert a copy of this License into the extracted document, and follow this License in all other respects regarding verbatim copying of that document.

## AGGREGATION WITH INDEPENDENT WORKS

A compilation of the Document or its derivatives with other separate and independent documents or works, in or on a volume of a storage or distribution medium, is called an “aggregate” if the copyright resulting from the compilation is not used to limit the legal rights of the compilation’s users beyond what the individual works permit. When the Document is included an aggregate, this License does not apply to the other works in the aggregate which are not themselves derivative works of the Document.

If the Cover Text requirement of section A is applicable to these copies of the Document, then if the Document is less than one half of the entire aggregate, the Document’s Cover Texts may be placed on covers that bracket the Document within the aggregate, or the electronic equivalent of covers if the Document is in electronic form. Otherwise they must appear on printed covers that bracket the whole aggregate.

## TRANSLATION

Translation is considered a kind of modification, so you may distribute translations of the Document under the terms of section A. Replacing Invariant Sections with translations requires special permission from their copyright holders, but you may include translations of some or all Invariant Sections in addition to the original versions of these Invariant Sections. You may include a translation of this License, and all the license notices in the Document, and any Warranty Disclaimers, provided that you also include the original English version of this License and the original versions of those notices and disclaimers. In case of a disagreement between the translation and the original version of this License or a notice or disclaimer, the original version will prevail.

If a section in the Document is Entitled “Acknowledgements”, “Dedications”, or “History”, the requirement (section A) to Preserve its Title (section A) will typically require changing the

actual title.

## TERMINATION

You may not copy, modify, sub-license, or distribute the Document except as expressly provided for under this License. Any other attempt to copy, modify, sub-license or distribute the Document is void, and will automatically terminate your rights under this License. However, parties who have received copies, or rights, from you under this License will not have their licenses terminated so long as such parties remain in full compliance.

## FUTURE REVISIONS OF THIS LICENSE

The Free Software Foundation may publish new, revised versions of the GNU Free Documentation License from time to time. Such new versions will be similar in spirit to the present version, but may differ in detail to address new problems or concerns. See <http://www.gnu.org/copyleft/>.

Each version of the License is given a distinguishing version number. If the Document specifies that a particular numbered version of this License “or any later version” applies to it, you have the option of following the terms and conditions either of that specified version or of any later version that has been published (not as a draft) by the Free Software Foundation. If the Document does not specify a version number of this License, you may choose any version ever published (not as a draft) by the Free Software Foundation.

## ADDENDUM: How to use this License for your documents

To use this License in a document you have written, include a copy of the License in the document and put the following copyright and license notices just after the title page:

Copyright © YEAR YOUR NAME. Permission is granted to copy, distribute and/or modify this document under the terms of the GNU Free Documentation License, Version 1.2 or any later version published by the Free Software Foundation; with no Invariant Sections, no Front-Cover Texts, and no Back-Cover Texts. A copy of the license is included in the section entitled “GNU Free Documentation License”.

If you have Invariant Sections, Front-Cover Texts and Back-Cover Texts, replace the “with...Texts.” line with this:

with the Invariant Sections being LIST THEIR TITLES, with the Front-Cover Texts being LIST, and with the Back-Cover Texts being LIST.

If you have Invariant Sections without Cover Texts, or some other combination of the three, merge those two alternatives to suit the situation.

If your document contains nontrivial examples of program code, we recommend releasing these examples in parallel under your choice of free software license, such as the GNU General Public License, to permit their use in free software.